

APPLY LUBRICANT TO ALL SEALS PRIOR TO INSTALLATION. DO NOT USE SILICONE TYPE LUBRICANTS. FOR PROPER ARM MOUNTING SEE IS1505.

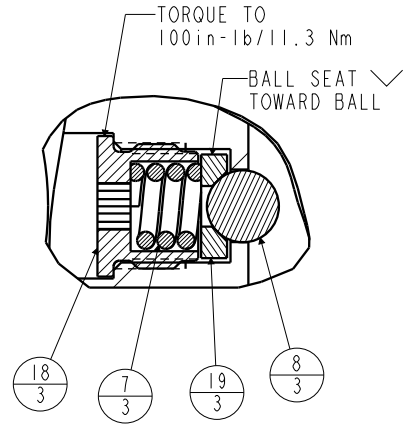

DETAIL A  
SCALE 1.500

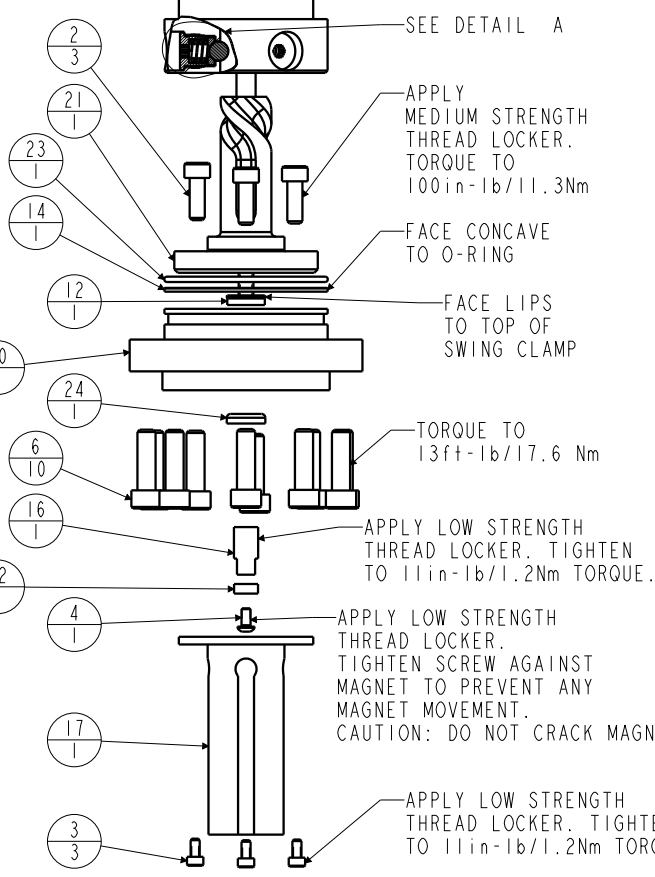
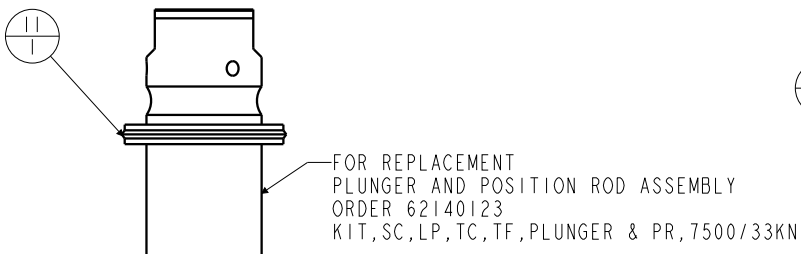

No.	QTY	PART No.	DESCRIPTION	Std. Seal Kit	FKM Seal Kit
N/A	N/A	IS1505	INSTRUCTION SHEET, ARM INSTALLATION		
N/A	N/A	6V711054	SEAL KIT, FKM		
N/A	N/A	60711054	SEAL KIT, STANDARD		
25	1	39V11051	WIPER, PRESS-IN, (1-1/2)	X	X
24	1	39V10029	WIPER, PRESS-IN, (1/4)	X	X
23	1	39H51002	O-RING, (-033)	X	39V51002
22	1	91100001	MAGNET, .130 x .312, PS		
21	1	81592132	CAM, SC, LP, 7500/33KN, LH, TC, PR		
20	1	81532115	CAP, END, SC, LP, 33KN/7500, PR		
19	3	81532108	SEAT, BALL, SC, LP, TC		
18	3	81532107	RETAINER, SC, LP, TC		
17	1	81500061	HOUSING, PS, MAG, SC, LP		
16	1	81500060	ADAPTOR, PS, MAG, SC, LP		
15	2	43068006	PLUG, 1/4 BSPP MALE		
14	1	39054017	BU RING, (-033)	X	39054023
13	1	39054016	BU RING, (1.5x.125x.063)	X	X
12	1	39052043	SEAL, LL, (1/4 X 1/8 X 1/8 X 1/2)	X	39V52043
11	1	39052030	SEAL, CROWN, 1-3/4x2-1/8x1/4	X	39V52030
10	2	39050042	O-RING, (-011)	X	39051025
9	1	39011075	SEAL, LL, (1-1/2 X 1/8 X 1/8 1-3/4)	X	39V11075
8	3	23650004	BALL, TUNGSTEN-CARBIDE .250		
7	3	23350066	SPRING, COMPRESSION		
6	10	21500304	SHCS, M6 X 1.0-6G X 20MM		
5	2	21500200	WASHER		
4	1	21500044	SCREW, CAP, BTNH, M3-0.5 X 6, SSTL		
3	3	21500043	SHCS, M3-0.5 X 6 ALY		
2	3	21500031	SHCS, M5 X 0.8 X 14, ALY		
1	2	21500019	SCREW, CAP, BTNH, M3 X 6, ALY		

**PARTS LIST**



VEKTEK, INC.  
1334 E. SIXTH AVE. P.O. BOX 625  
EMPORIA, KS. 66801 U.S.A.

ASSEMBLIES AFFECTED  
41463322PS  
41463322PSF

PARTS LIST, ASSY, SC, LP, TC, TF, 33KN, DA, LH, PS  
SIZE A  
MPL7223  
REV D

D	5762	RELEASE	JDW	07/15/25
REV	IN ACCORDANCE WITH ECN	EFFECTIVE DATE	REVISED BY	DATE
DRW BY:	JDW	DRAWING STATUS: <b>Released</b>		
DATE:	10/16/13	PRODUCTION APPROVED FOR RELEASED STATUS ONLY		

